

PowerTech™ M

4045TF280 Diesel Engine

Industrial Engine Specifications

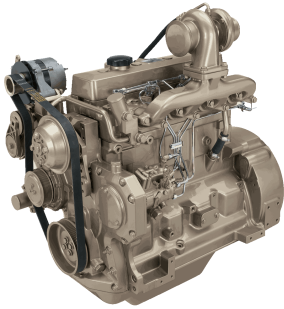

4045TF280 shown

Engine dimensions

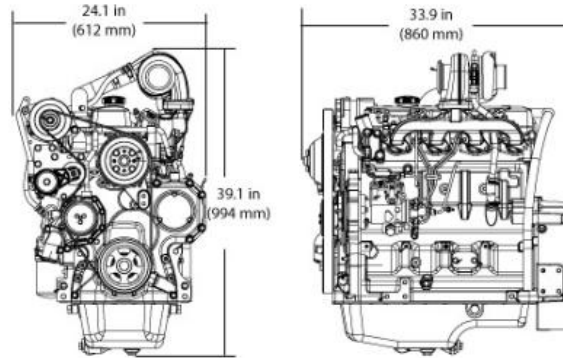

Dimensions may vary according to options selected. Call your distributor for more information.

Certifications

CARB
EPA Tier 3
EU Stage III A

General data

Model	4045TF280	Length - mm (in)	860 (33.9)
Number of cylinders	4	Width - mm (in)	612 (24.1)
Displacement - L (cu in)	4.5 (275)	Height-- mm (in)	994 (39.1)
Bore and Stroke-- mm (in)	106 x 127 (4.17 x 5.00)	Weight, dry-- kg (lb)	396 (873)
Compression Ratio	19.0:1		
Engine Type	In-line, 4-Cycle		
Aspiration	Turbocharged		

Performance data range

Application ratings	Intermittent
Rated power/Rated speed	56-63 kW (75-84 hp) @2400rpm
Peak power	56-63 kW (75-84 hp) @2400rpm
Power bulge	NA @ NA rpm
Peak torque	271-302 N.m (200-223ft-lb) @1700rpm
Torque rise	NA

The Industrial Intermittent engine power rating is for applications that operate at varying loads and speeds, and do not fit the Industrial Heavy-Duty rating information.

Power output is within + or - 5% at standard SAE J 1995 and ISO 3046.

Features and benefits

2-Valve Cylinder Head

- Cross flow head design that provides excellent breathing from a lower cost two-valve cylinder head

Mechanical Rotary Fuel Pump

- The timing and fuel injection pressures are optimized to maximize performance and fuel economy at a given rated speed

Fixed Geometry Turbocharger

- Fixed geometry turbochargers are sized for a specific power range and optimized to provide excellent performance across the entire torque curve. They are also designed to maximize fuel economy between the engine's rated speed and peak torque.

Turbocharged

- In turbocharged engines, the air is pre-compressed. Due to the higher pressure, more air is supplied into the combustion chamber allowing a corresponding increase in fuel injection which results in greater engine output

Compact Size

- Mounting points are the same as Tier 2/Stage II engine models

Additional Features

- Self-adjusting poly-vee fan drive
- Forged-steel connecting rods
- Replaceable wet-type cylinder liners
- Either-side service
- 500-hour oil change
- Optional final fuel filter with water separator and water-in-fuel sensor
- Optional balancer shafts